



PIPE PIER® Adjustable Elevation Kit A for use with PIPE PIER® 150

Application: Pipe and conduit support for rooftop applications. Uses standard strut and accessories. Designed to allow a soft pliable barrier between the piping system and the roof or floor surface. The adjustable elevation kit allows the pipe to maintain a set elevation while the support follows the slope of the roof and saves the labor of elbowing around parapets or other obstructions.

Material: The base of the support is made of a closed cell polyethylene black foam which is chemically bonded to a 14 gauge galvanized plate. The plate is mechanically fastened to a 12 gauge galvanized strut frame.

Specification: Piping on roof surfaces shall be supported by a polyethylene foam block with an integral strut channel for receiving standard strut clamps and accessories. Pipe Pier shall be installed according to manufacturer's recommendations. Roof pipe supports shall be spaced according to industry standards and shall be installed to allow for expansion and contraction.

Features

- Top loading design enables the pipe to be easily lowered into the pipe support.
- Elevation kits are shipped from the factory fully assembled.
- Easily adjusts to elevation changes of the roof.
- The 12" W X 12" L square base provides a large footprint to distribute the weight of the piping system.
- Prolongs rooftop life and reduces roof repairs.
- Standardizes pipe support installations.
- Provides many mounting positions and clamping or roller options.
- Adaptable to most all configurations.
- Absorbs vibration, shock, and cushions roof surface.
- Easy and proper anchoring and fastening of pipe systems.
- Cushioning surface accommodates expansion and contraction of piping.
- Resistant to deterioration: repels rain, snow and ice.
- Infinitely adjustable height range:
 - Minimum height is 6" from roof deck.
 - Maximum height is 19" from roof deck.
- Maximum pipe size is 6" OD.
- Maximum center load is 150 pounds.
- Support weighs approximately 11 pounds.
- Complies with Uniform Mechanical Codes:
 - ('97) 1312.2 for gas piping.
 - ('97) 1201.1.6.2 for hydronic piping.

Pipe Pier is a trademark of PIPE PIER Inc. US Patent 5,855,342

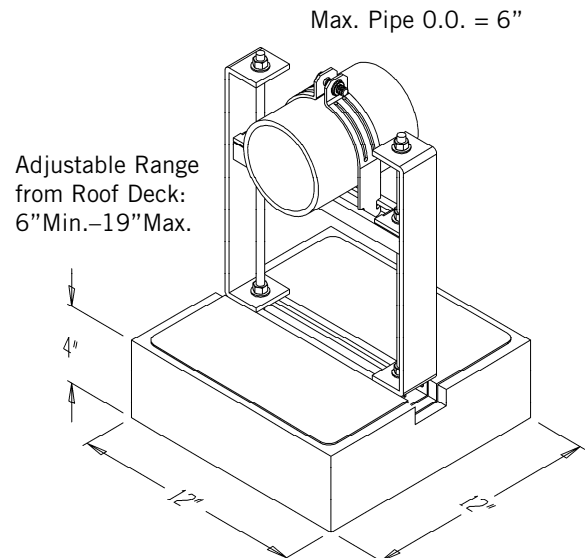

Model PP150E w/Kit A