



PIPE PIER® support blocks have been designed and engineered specifically for rooftop and raised floor applications. The maximum center load for the PIPE PIER® 150 is 150 lbs per support block. Piping should be attached using standard strut clamps, rollers, or other approved accessories. Recommended maximum spacing between support blocks is 10 feet.

**Components**

- A. Closed-cell, medium density, black polyethylene foam Ethafoam HS 45\*
- B. 14 Gauge Strut Channel
- C. Hot melt adhesive-bonding strut to foam block BONDMASTER INSTAWELD 34-3378
- D. 14 Gauge Galvaneal Sheet Metal

*\*Trademark of Dow Chemical Co.*

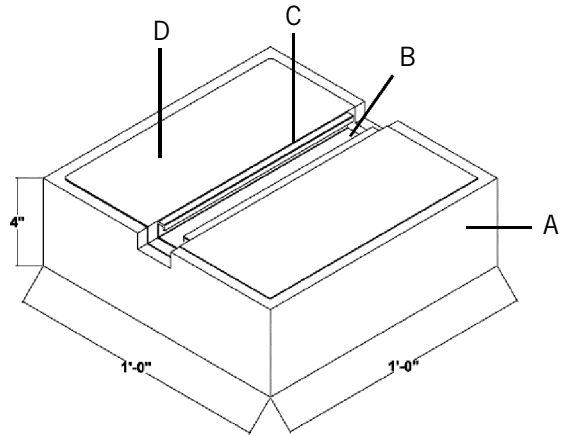

**Ethafoam HS 45\*** polyethylene foam offers excellent strength, resistance to creep under loadings up to 5.0 psi, vibration & shock absorbency and water resistance characteristics. Ethafoam HS 45 has successfully passed MVSS 302 flammability testing and meets or exceeds the requirements for U.S. Federal Standard PPP-C-1752C, Type III.

*\*Trademark of Dow Chemical Co.*

Physical Properties	Test Method	Direction	Value
Density	ASTM D 3575, Suffix W, Method B	N/A	3.9 pcf
Compression Set	ASTM D 3575, Suffix B	Vertical	<15%
Compression Creep @ 5.0 psi (1000 hr/72 F)	ASTM D 3575, Suffix BB	Vertical	<10%
Thermal Stability	ASTM D 3575, Suffix S	N/A	<1%
Water Absorption	ASTM D 3575, Suffix L	N/A	<0.2 lb/sq ft

**14 Gauge Strut Channel & 14 Gauge Galvaneal Sheet Metal**

The 14 gauge strut channel is cold roll-formed from high quality carbon steel. The channel finish is hot dipped mill galvanized. The raw steel used conforms to ASTM 570 GR 33 and ASTM A446 GR A. The strut is welded to the formed sheet metal and then it is hot glued to the foam block using the Bondmaster Instaweld 34-3378. This allows the load to be evenly distributed across the surface of the support block.

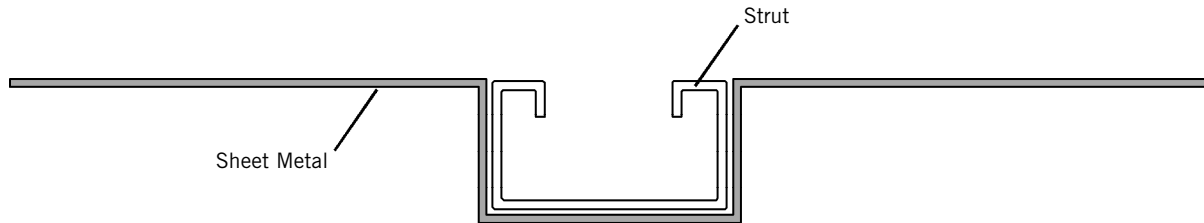

**BONDMASTER INSTAWELD 34-3378** is a sprayable heat & moisture-resistant hot melt adhesive. It has a 350 degree melting point and is applied by a nozzle applicator during the manufacturing process. It conforms to MS-CC926.

U.S. Patent No. 5855342, U.S. Patent No. 6305650, U.S. Patent No. 6679461, Other patents pending